

A SHEET

REV.

C
33411

D
46380

LAST REV: D
DESCRIPTION:
ID. CHANGED FROM .794 +.003/-.000 TO .800 ON ID.
REVISION DATE: 9/29/2020
DEMA NUMBER ADDED.

如图产品，数量35000个，
材质不锈钢304（最好是可焊接的304牌号）
纸箱包装18kgs一箱

单位：英寸
壁厚：0.049

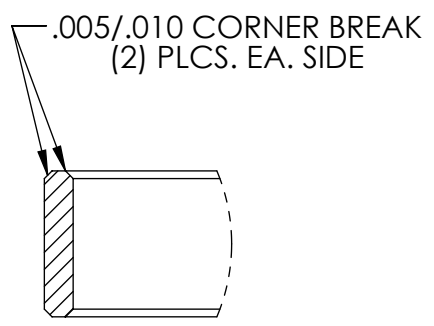

**DETAIL B
SCALE 4 : 1**

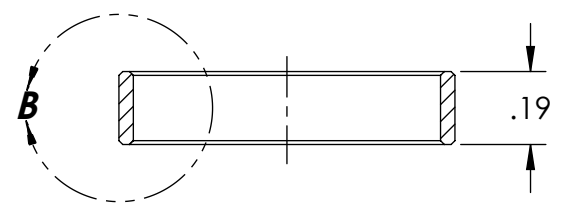
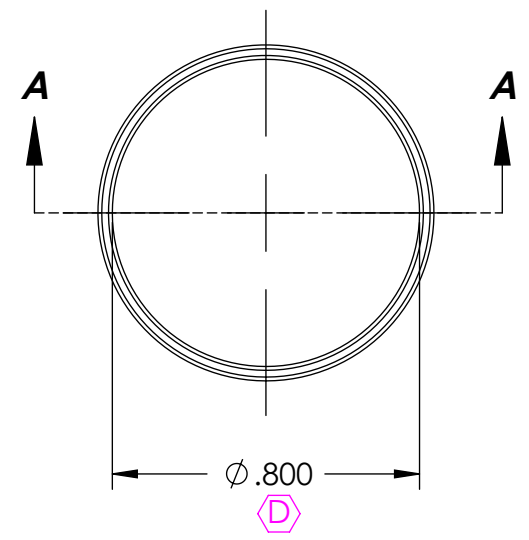

SECTION A-A

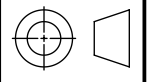
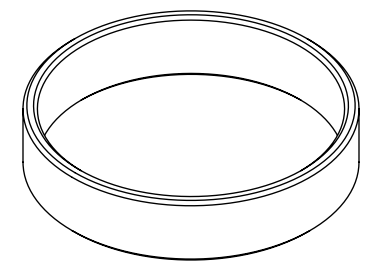

TOLERANCES: COMPLY WITH ENG SPEC. 2A DECIMAL: .XXX ±.005" .XX ±.010" FRACTIONAL: ±1/64" ANGULAR: ±1/2°	MATERIAL 7/8 OD. X .777 ID. 18 GA. (.049 THK) TYPE 304 STAINLESS STEEL WELDED TUBING.		FINISH NONE		RING			
	HARDNESS -	SCALE 2:1	DATE 5/13/08	DRAWN BY RDK				