

PART NUMBER: 300AJ10-AA  
OP SEQ 10: PC-S

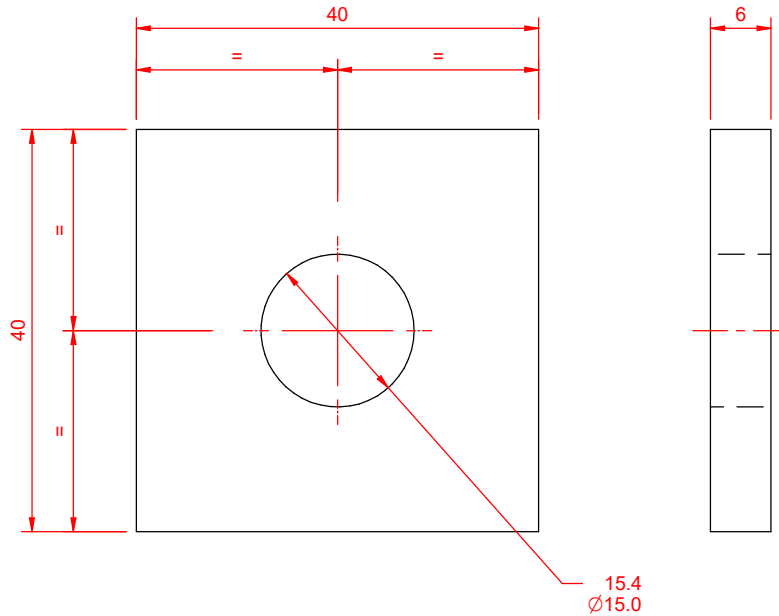

UNCONTROLLED COPY WHEN RELEASED

NOTES: IF IN DOUBT ASK

1. ALL DIMENSIONS IN MILLIMETRES
2. PART NUMBER REFERENCE:  
325AJ10-GA
3. FINISH & MATERIAL REFERENCE '\$\$':  
AA = MILD STEEL  
GA = HOT DIP GALVANIZED MILD STEEL  
TO BS EN ISO 1461
4. REMOVE ALL BURRS

PART NUMBER: 325AJ10-GA  
PACKED PART

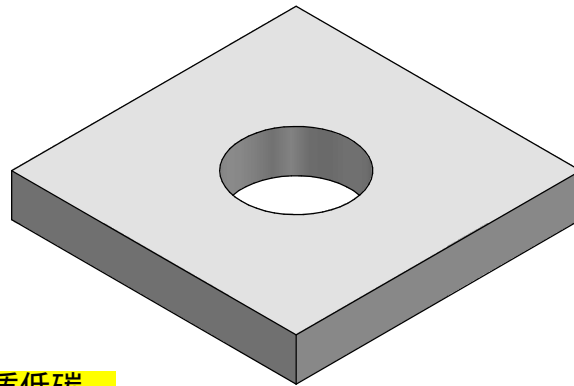

如图四方垫圈，150千，材质低碳，  
表面热镀锌，去毛刺，  
小盒装，欧式托盘

03	STRUCTURE UPDATED	DO	MR	IH	04/10/22
02	CORRECTIONS MADE	SJ	MR	IH	11/11/15
01	MANUFACTURING RELEASE	C.S	M.R	I.H	15/09/14
REV	DETAILS	DRN	CHK	APR	DATE

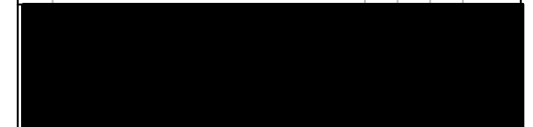

THIS DRAWING IS THE COPYRIGHT OF VANTRUNK LTD AND IS NOT TO BE REPRODUCED OR PASSED TO THIRD PARTIES WITHOUT WRITTEN CONSENT

SCALE:	TOLERANCES (UOS):	3rd ANGLE:
NTS	±1.0mm ±1.0°	

DRAWING TITLE:  
**Square Washer**

DRAWING NUMBER:  
TYPE: PART NUMBER: REVISION:  
**PROD\_ 325AJ10-GA \_03**