

Notes:

1. Dimensions not tolerated should be made in accordance with PN-EN 22768-1:1999-f.
2. The dimension in brackets is a control dimension.
3. Sharp edges should be blunted.
4. Electrolytic coating EN 12540 - Fe/Zn8.
5. Material 1,0037 (S235JR) 材质：S235JR 数量：10000PCS
6. Weight 0,13kgs
7. Bolts must have a manufacturer's mark and class on the heads
8. Class 8,8

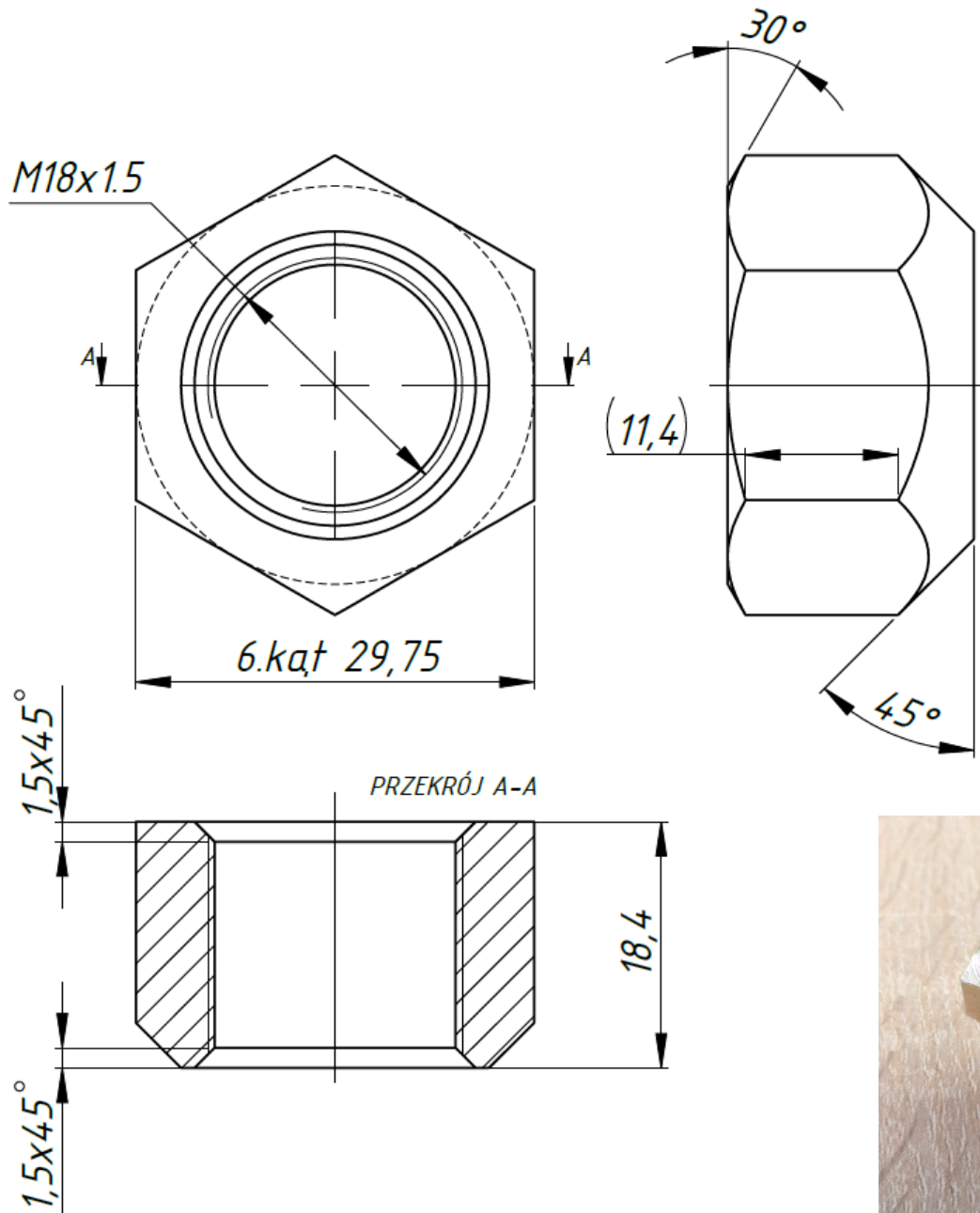

05-22-P004



Remarks:

1. Dimensions not tolerated should be made in accordance with PN-EN 22768-1:1999-f.
2. Sharp edges should be blunted.
3. Electrolytic coating EN 12540 - Fe/Zn8.
4. Material 1,0037 (S235JR) 材质 : S235JR 数量 : 10000PCS
5. Weight 0,07kgs
6. Marking: Class and manufacturer's mark
7. nuts must be made at 8 Class according to DIN EN ISO 898-2